

Specifications

Nominal Voltage		12 V
Capacity (25°C)	10HR(10.8V)	9.0Ah
	5HR(10.5V)	8.4Ah
	1HR(9.60V)	6.4Ah
Dimension	Length	151 ± 1.5mm (5.94inch)
	Width	65 ± 1mm (2.56inch)
	Height	94 ± 1mm (3.70inch)
	Total Height	100 ± 1mm (3.94inch)
Approx. Weight		2.65kg (5.84lbs) ± 5%
Terminal type		T1/T2
Internal resistance (Fully charged, 25°C)		Approx. 19m Ω
Capacity affected by temperature (20HR)	40°C	102%
	25°C	100%
	0°C	85%
	-15°C	65%
Self-discharge (25°C)	3 month	Remaining Capacity: 91%
	6 month	Remaining Capacity: 82%
	12 month	Remaining Capacity: 65%
Nominal operating temperature		25°C ± 3°C (77°F ± 5°F)
Operating temperature range	Discharge	-15°C ~ 50°C (5°F ~ 122°F)
	Charge	-10°C ~ 50°C (14°F ~ 122°F)
	Storage	-20°C ~ 50°C (-4°F ~ 122°F)
Float charging voltage(25°C)		13.60 to 13.80V Temperature compensation: -18mV/°C
Cyclic charging voltage(25°C)		14.50 to 14.90V Temperature compensation: -30mV/°C
Maximum charging current		2.7A
Terminal material		Copper
Maximum discharge current		135A(5 sec.)
Designed floating life(20°C)		15 years

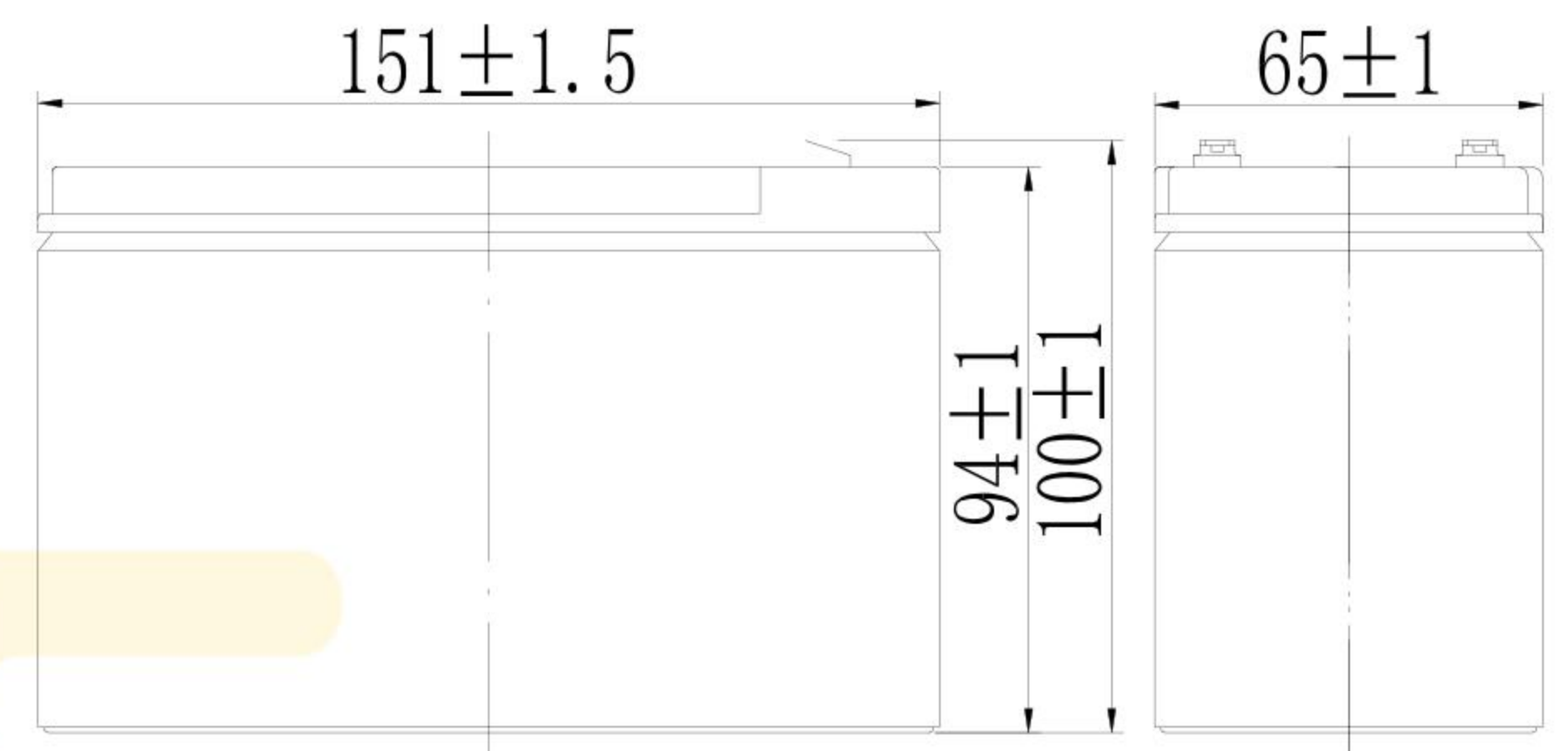

Dimensions



Terminal

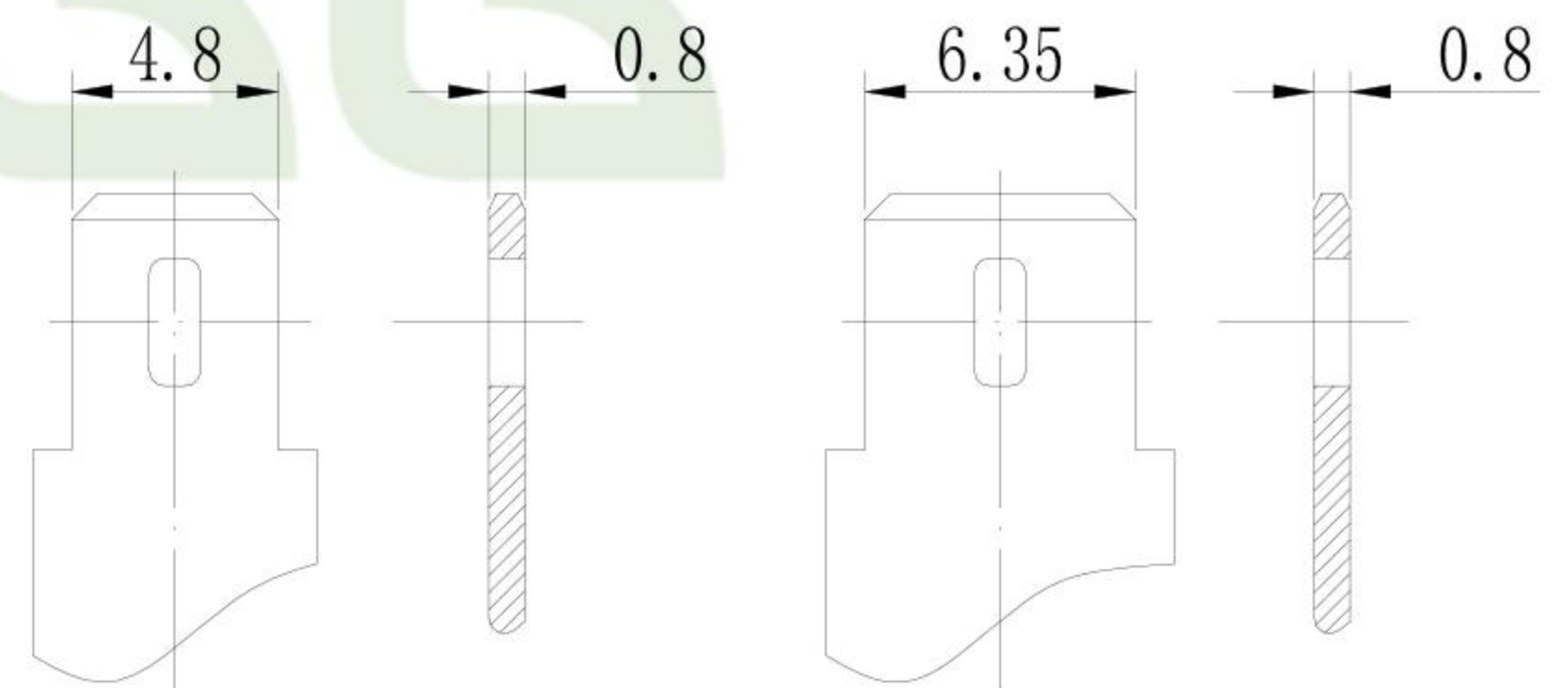

Terminal T1

Terminal T2

- ◆ Absorbent glass mat technology;
- ◆ Recognized by UL & CE;
- ◆ ABS container.

Constant Current Discharge Characteristics (A, 25°C)

F.V/TIME	5min	10min	15min	30min	60min	2h	3h	4h	5h	10h	20h
9.60V	36.4	23.0	18.4	10.3	6.42	3.51	2.52	2.02	1.71	0.93	0.48
9.90V	35.3	22.3	18.0	10.1	6.32	3.49	2.50	2.01	1.70	0.93	0.47
10.2V	33.9	21.4	17.3	9.75	6.17	3.46	2.49	1.99	1.69	0.92	0.47
10.5V	32.4	20.4	16.7	9.52	6.04	3.40	2.47	1.98	1.68	0.92	0.47
10.8V	30.6	19.3	15.8	9.16	5.86	3.31	2.39	1.92	1.62	0.90	0.46

Constant Power Discharge Characteristics (Watt, 25°C)

F.V/TIME	5min	10min	15min	30min	60min	2h	3h	4h	5h	10h	20h
9.60V	406	259	210	117	74.3	41.0	30.0	24.0	20.4	11.2	5.75
9.90V	394	251	204	115	73.2	40.8	29.7	23.8	20.3	11.2	5.73
10.2V	378	241	198	112	71.3	40.5	29.5	23.7	20.2	11.1	5.69
10.5V	361	230	190	109	69.9	39.8	29.3	23.5	20.1	11.0	5.66
10.8V	341	218	180	105	67.8	38.9	28.4	22.8	19.4	10.8	5.55

Note: The above characteristics data can be obtained within three charge/discharge cycles.

Discharge Characteristics(25°C)

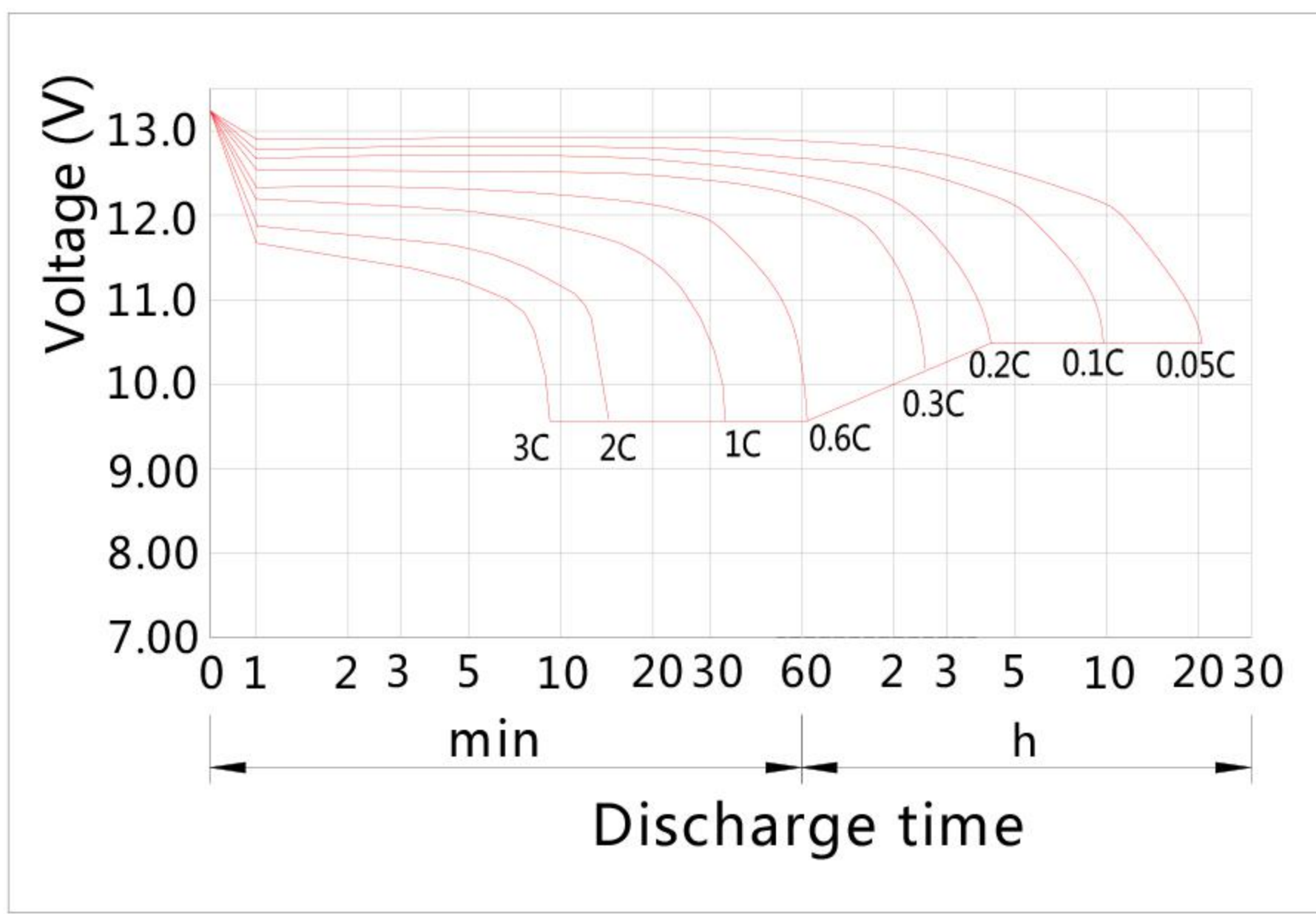

Charging Characteristics(25°C)

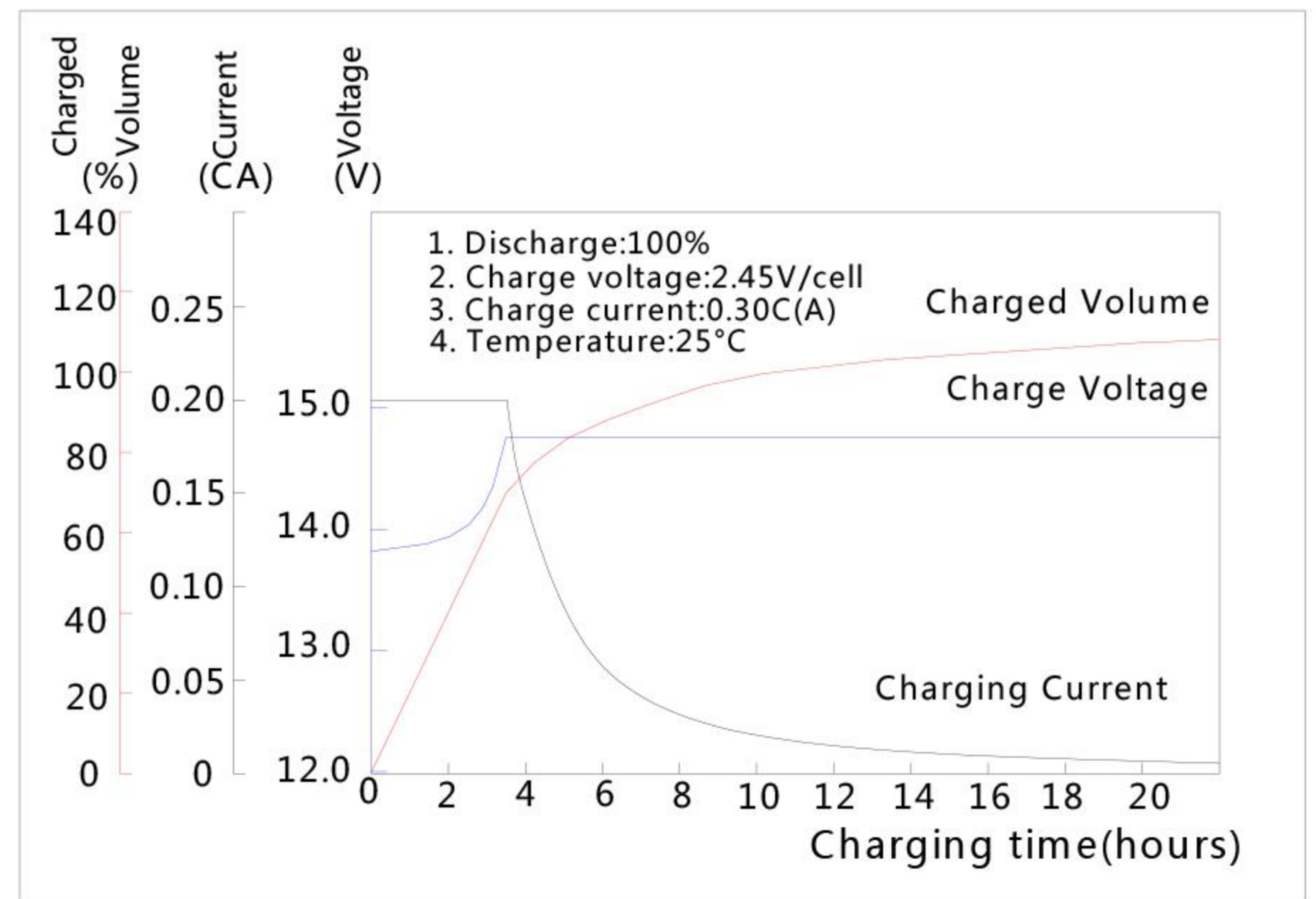

Effect of Temperature on Capacity

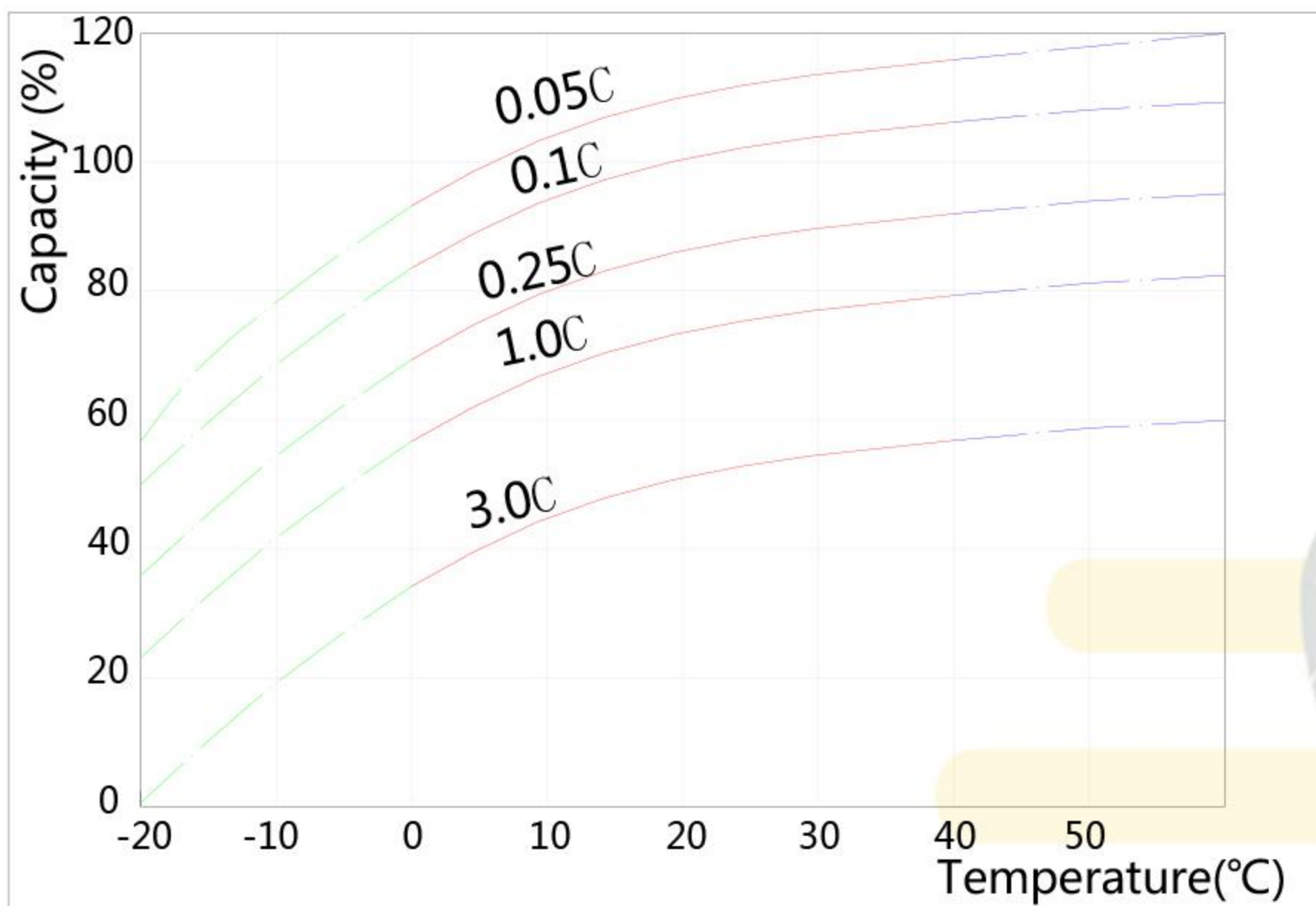

Self-discharge Characteristics

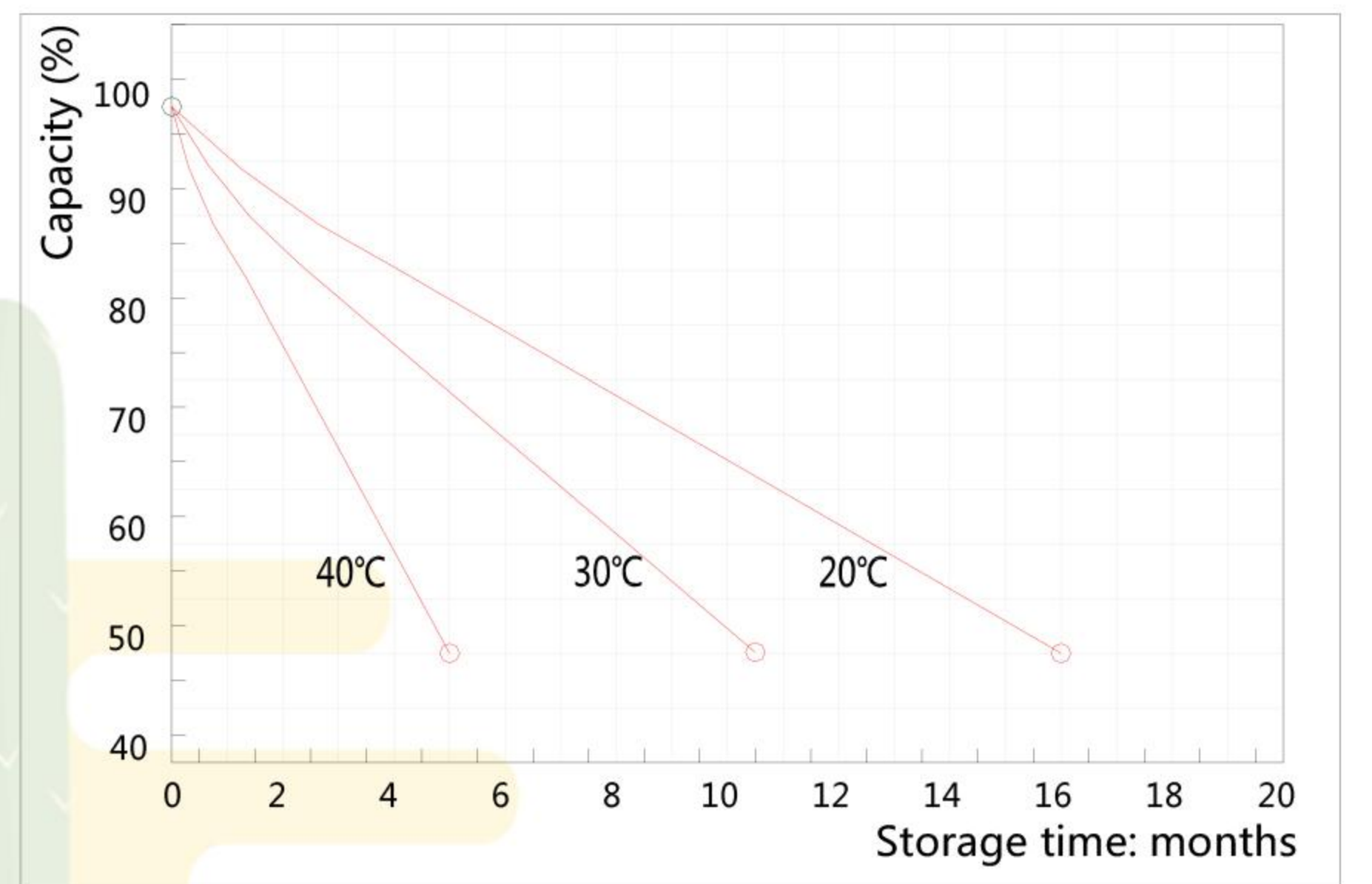

The Relationship for Open Circuit Voltage and Residual Capacity (25°C)

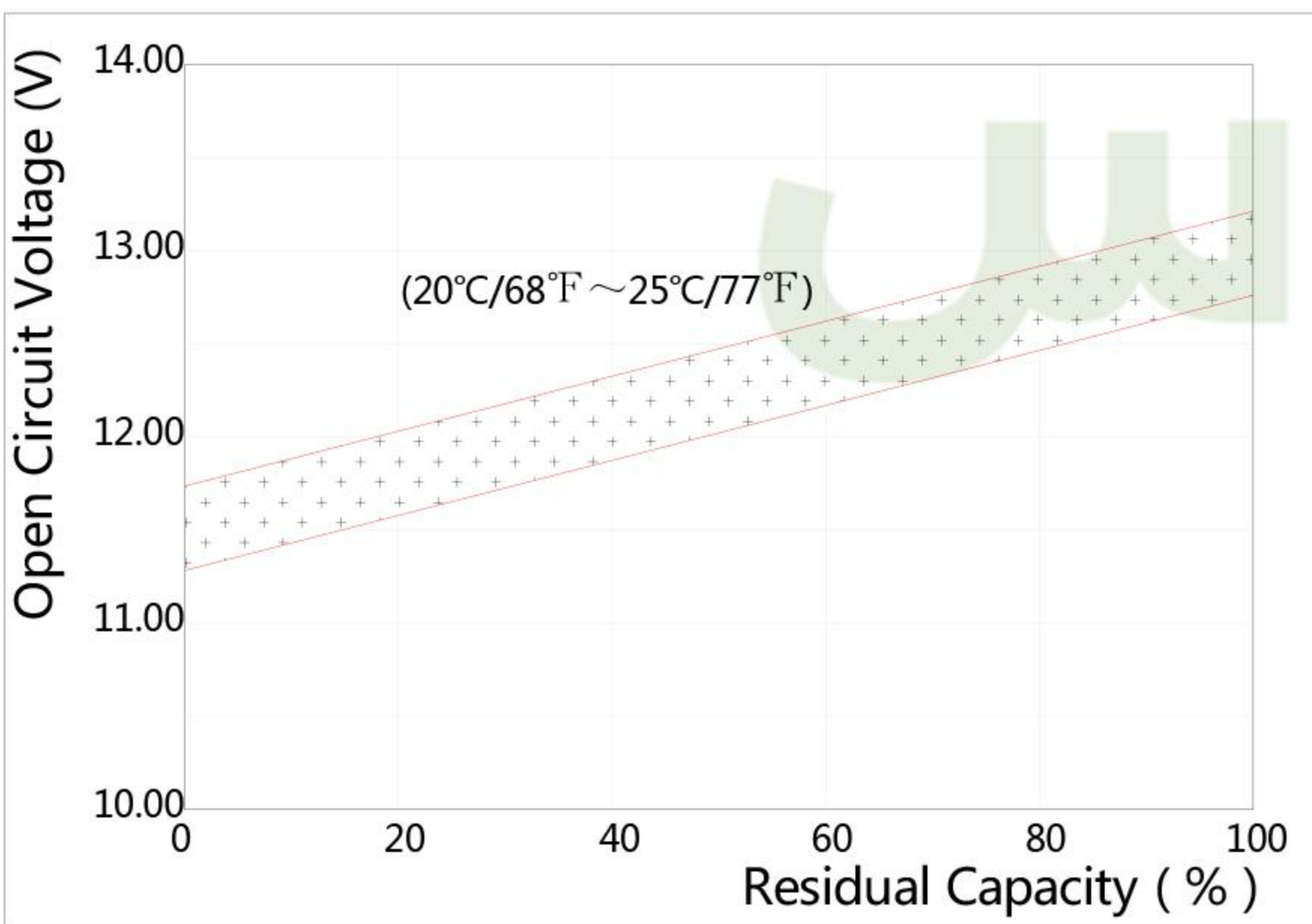

The Relationship for Charging Voltage and Temperature

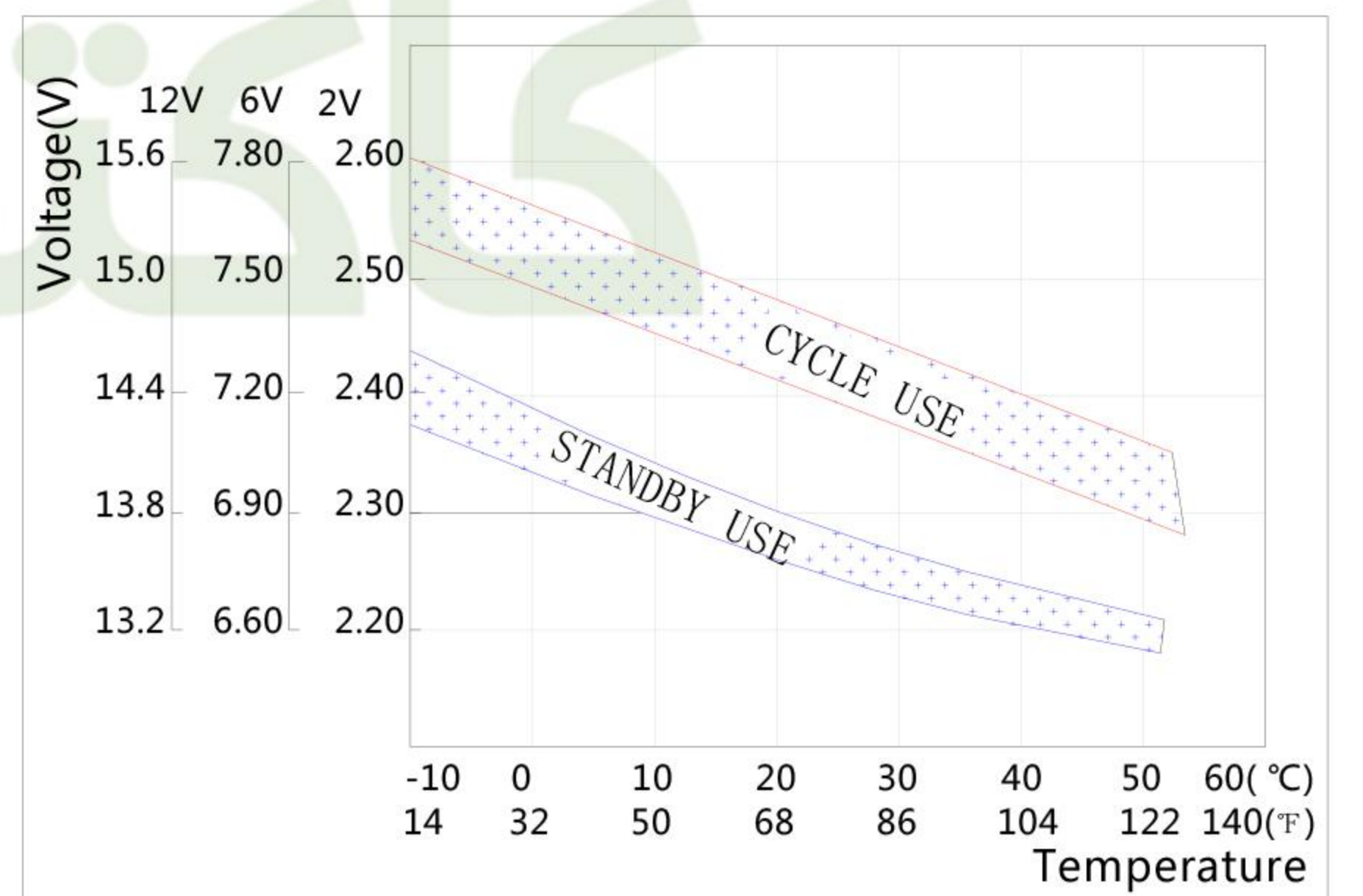

Floating Life on Temperature

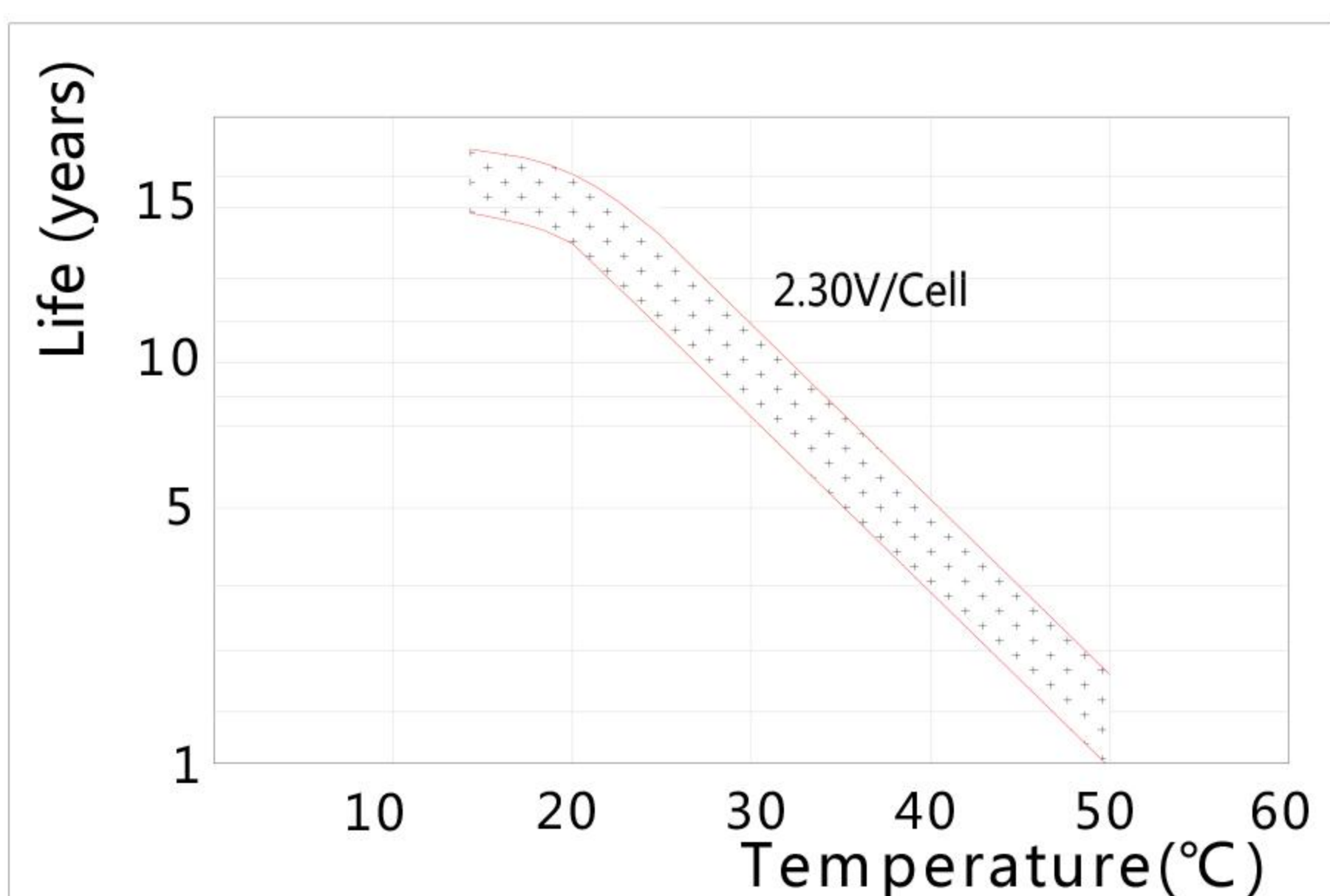

Cycle Life on D.O.D(25°C)

