

**Specifications**

Nominal Voltage		12 V
Capacity (25°C)	10HR(10.8V)	7.0Ah
	5HR(10.5V)	6.35Ah
	1HR(9.60V)	4.86Ah
Dimension	Length	151 ± 1.5mm (5.94inch)
	Width	65 ± 1mm (2.56inch)
	Height	94 ± 1mm (3.70inch)
	Total Height	100 ± 1mm (3.94inch)
Approx. Weight		2.35kg (5.18lbs) ± 5%
Terminal type		T1/T2
Internal resistance (Fully charged, 25°C)		Approx. 28mΩ
Capacity affected by temperature (20HR)	40°C	102%
	25°C	100%
	0°C	85%
	-15°C	65%
Self-discharge (25°C)	3 month	Remaining Capacity: 91%
	6 month	Remaining Capacity: 82%
	12 month	Remaining Capacity: 65%
Nominal operating temperature		25°C ± 3°C (77°F ± 5°F)
Operating temperature range	Discharge	-15°C ~ 50°C (5°F ~ 122°F)
	Charge	-10°C ~ 50°C (14°F ~ 122°F)
	Storage	-20°C ~ 50°C (-4°F ~ 122°F)
Float charging voltage(25°C)		13.60 to 13.80V Temperature compensation: -18mV/°C
Cyclic charging voltage(25°C)		14.50 to 14.90V Temperature compensation: -30mV/°C
Maximum charging current		2.1A
Terminal material		Copper
Maximum discharge current		105A(5 sec.)
Designed floating life(20°C)		15 years

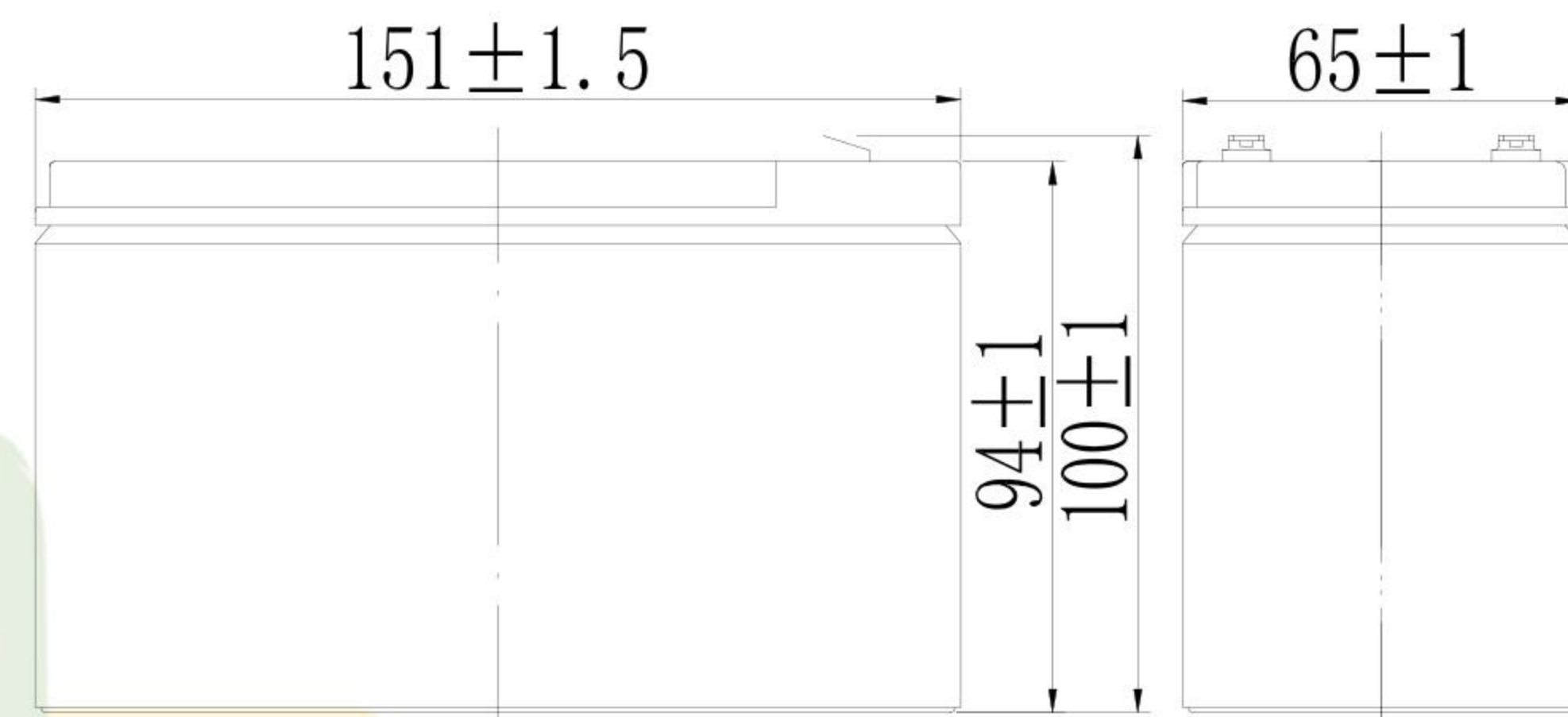

**Dimensions**



**Terminal**

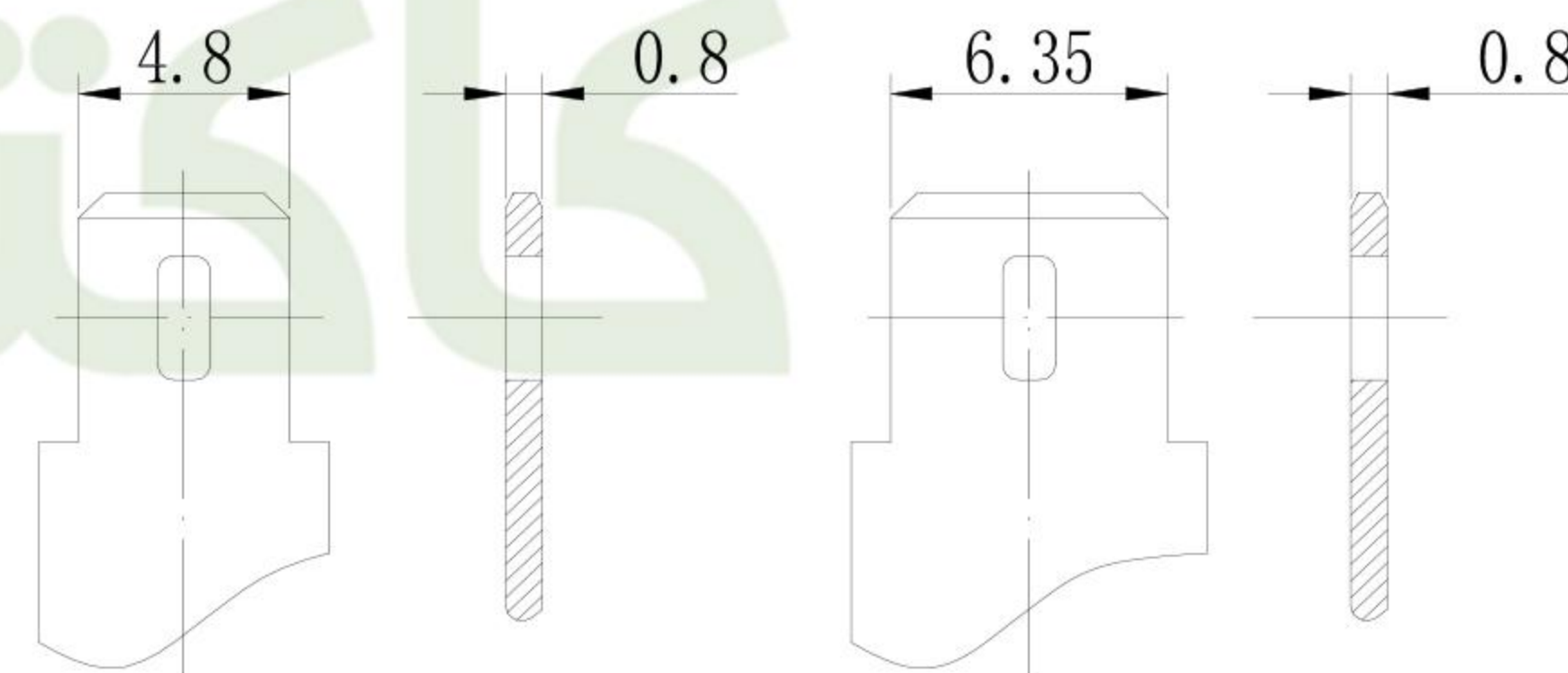

Terminal T1

Terminal T2

- ◆ Absorbent glass mat technology;
- ◆ Recognized by UL & CE;
- ◆ ABS container.

**Constant Current Discharge Characteristics (A, 25°C)**

F.V/TIME	5min	10min	15min	30min	60min	2h	3h	4h	5h	10h	20h
9.60V	27.8	17.5	14.0	7.83	4.86	2.65	1.91	1.53	1.29	0.72	0.370
9.90V	26.9	17.0	13.7	7.67	4.78	2.64	1.90	1.52	1.29	0.72	0.370
10.2V	25.8	16.3	13.2	7.43	4.67	2.62	1.88	1.51	1.28	0.71	0.370
10.5V	24.7	15.6	12.7	7.25	4.57	2.58	1.87	1.50	1.27	0.71	0.365
10.8V	23.3	14.7	12.1	6.99	4.43	2.51	1.81	1.45	1.23	0.70	0.365

**Constant Power Discharge Characteristics (Watt, 25°C)**

F.V/TIME	5min	10min	15min	30min	60min	2h	3h	4h	5h	10h	20h
9.60V	310	197	160	89.6	56.3	31.1	22.7	18.1	15.5	8.5	4.41
9.90V	300	192	156	87.8	55.5	30.9	22.5	18.0	15.4	8.4	4.40
10.2V	288	183	151	85.2	54.0	30.7	22.4	17.9	15.3	8.4	4.38
10.5V	276	176	145	83.2	52.9	30.1	22.2	17.8	15.2	8.3	4.35
10.8V	260	167	138	80.1	51.3	29.4	21.5	17.3	14.7	8.2	4.30

Note: The above characteristics data can be obtained within three charge/discharge cycles.



Discharge Characteristics(25°C)

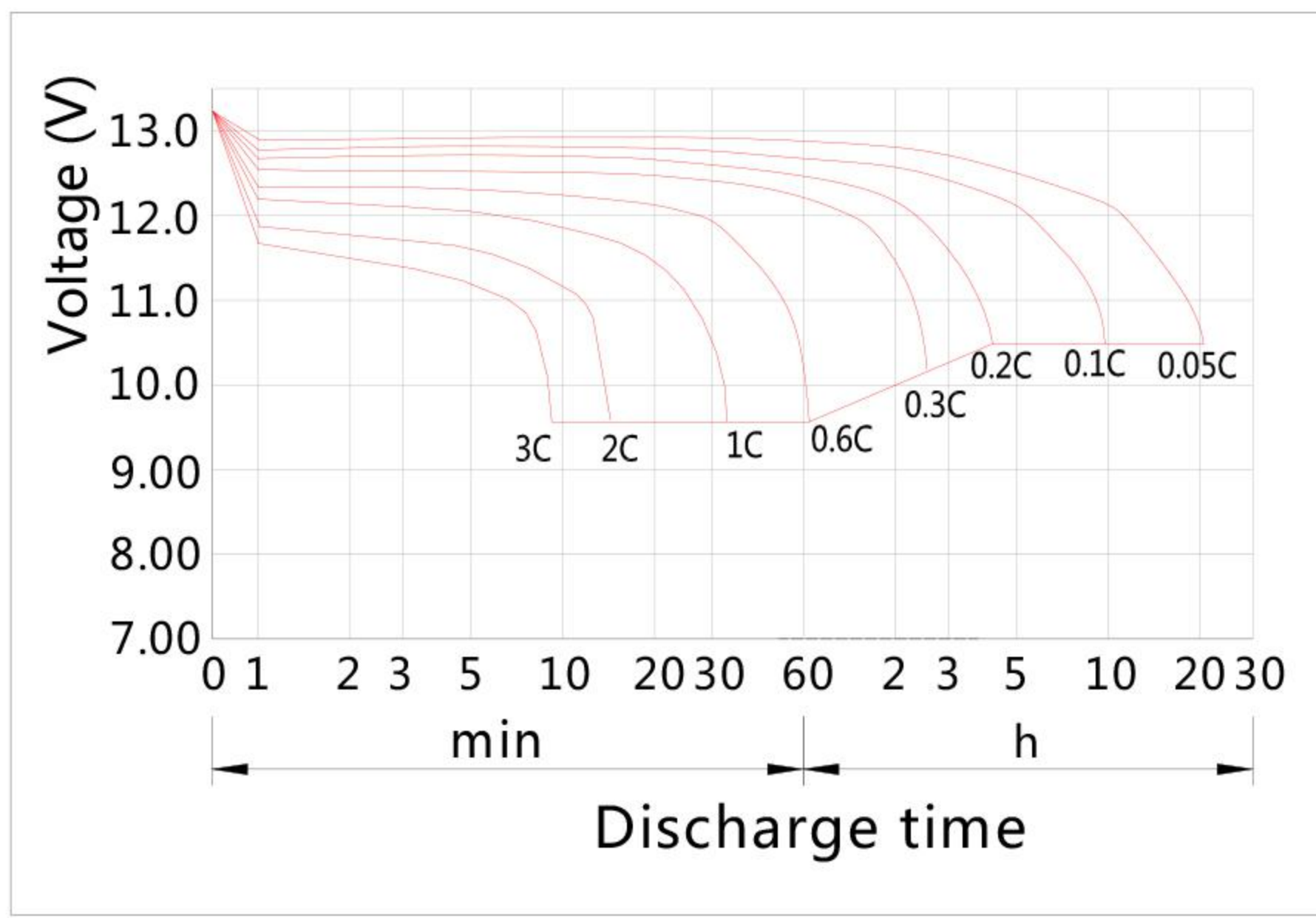

Charging Characteristics(25°C)

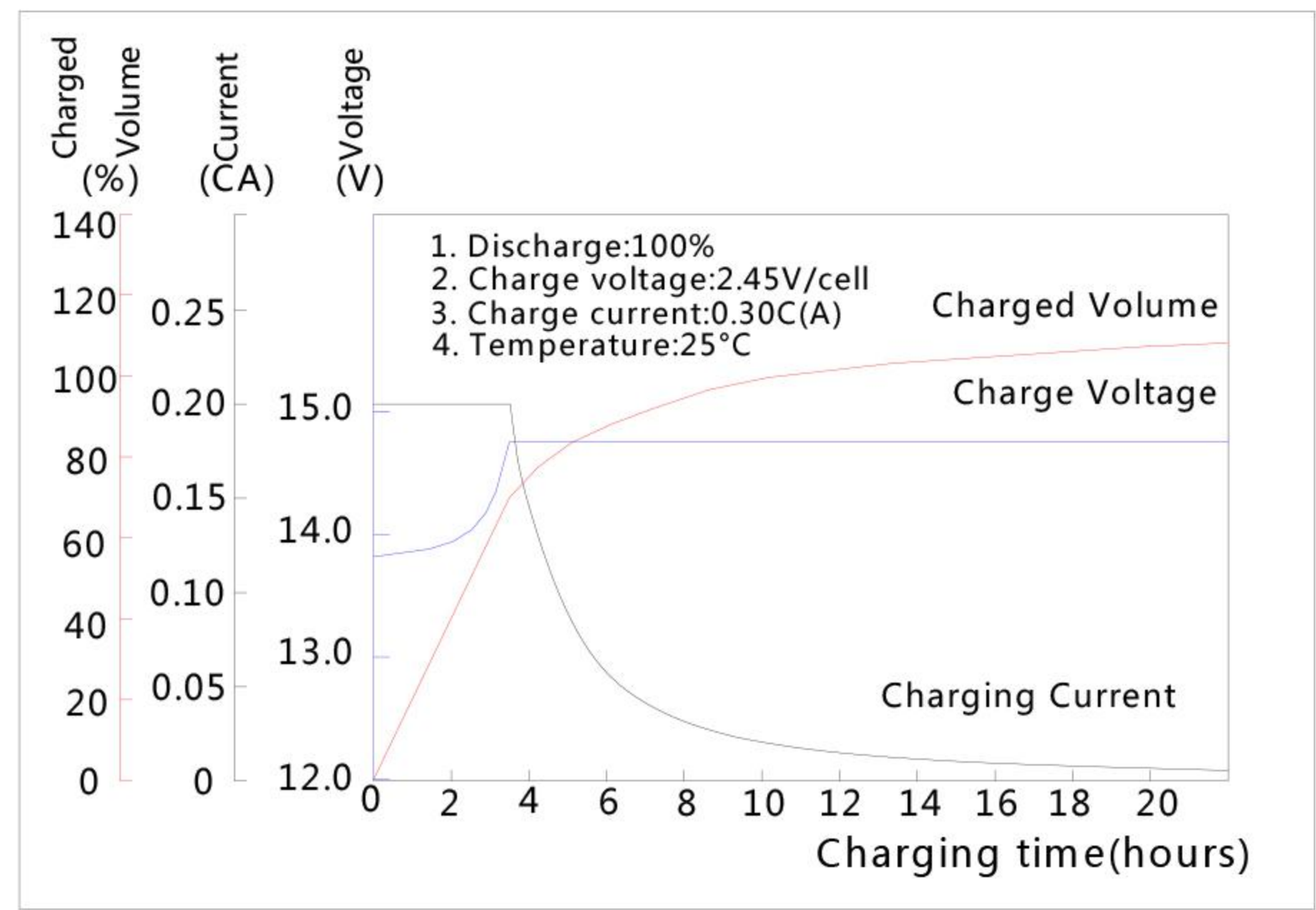

Effect of Temperature on Capacity

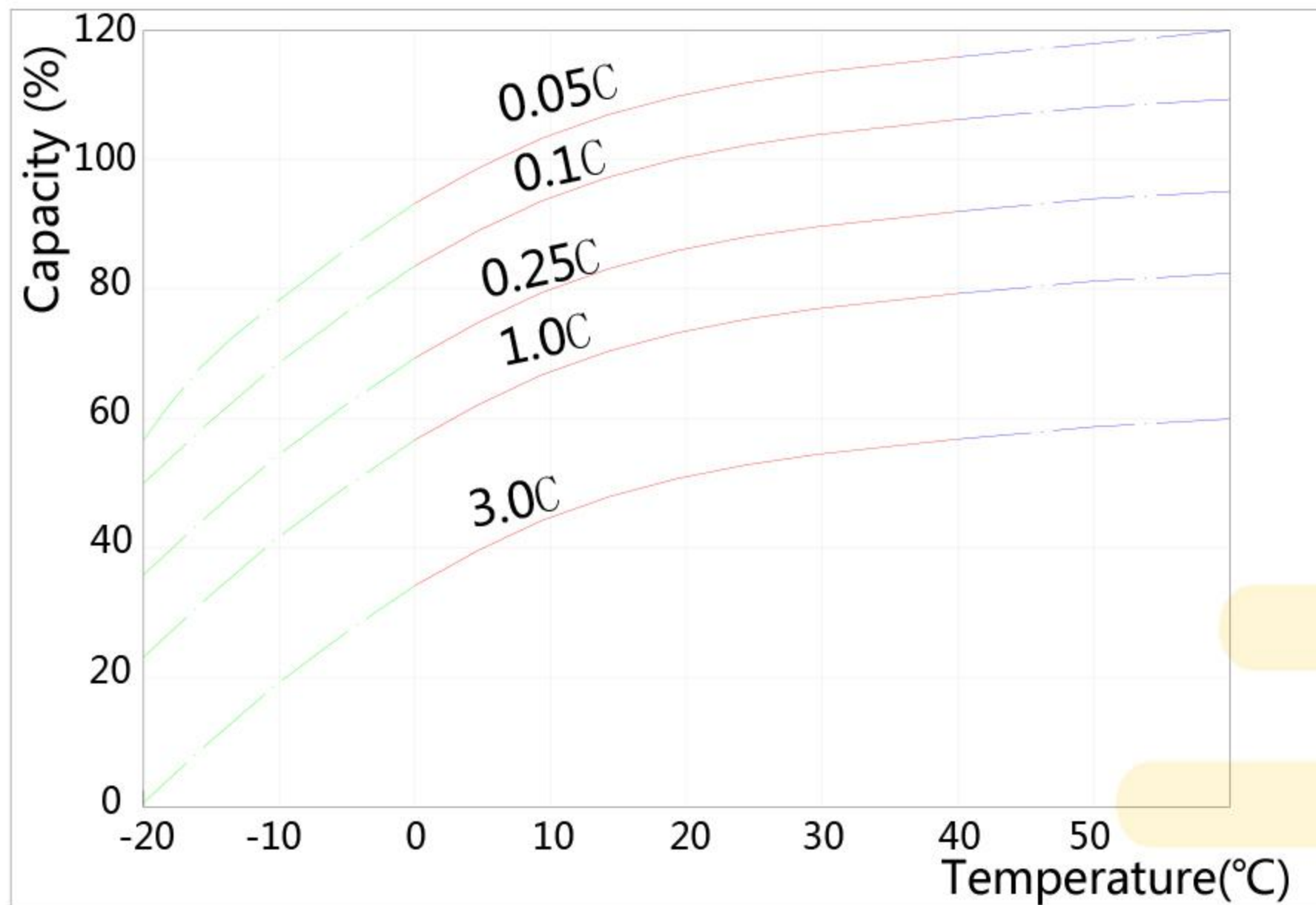

Self-discharge Characteristics

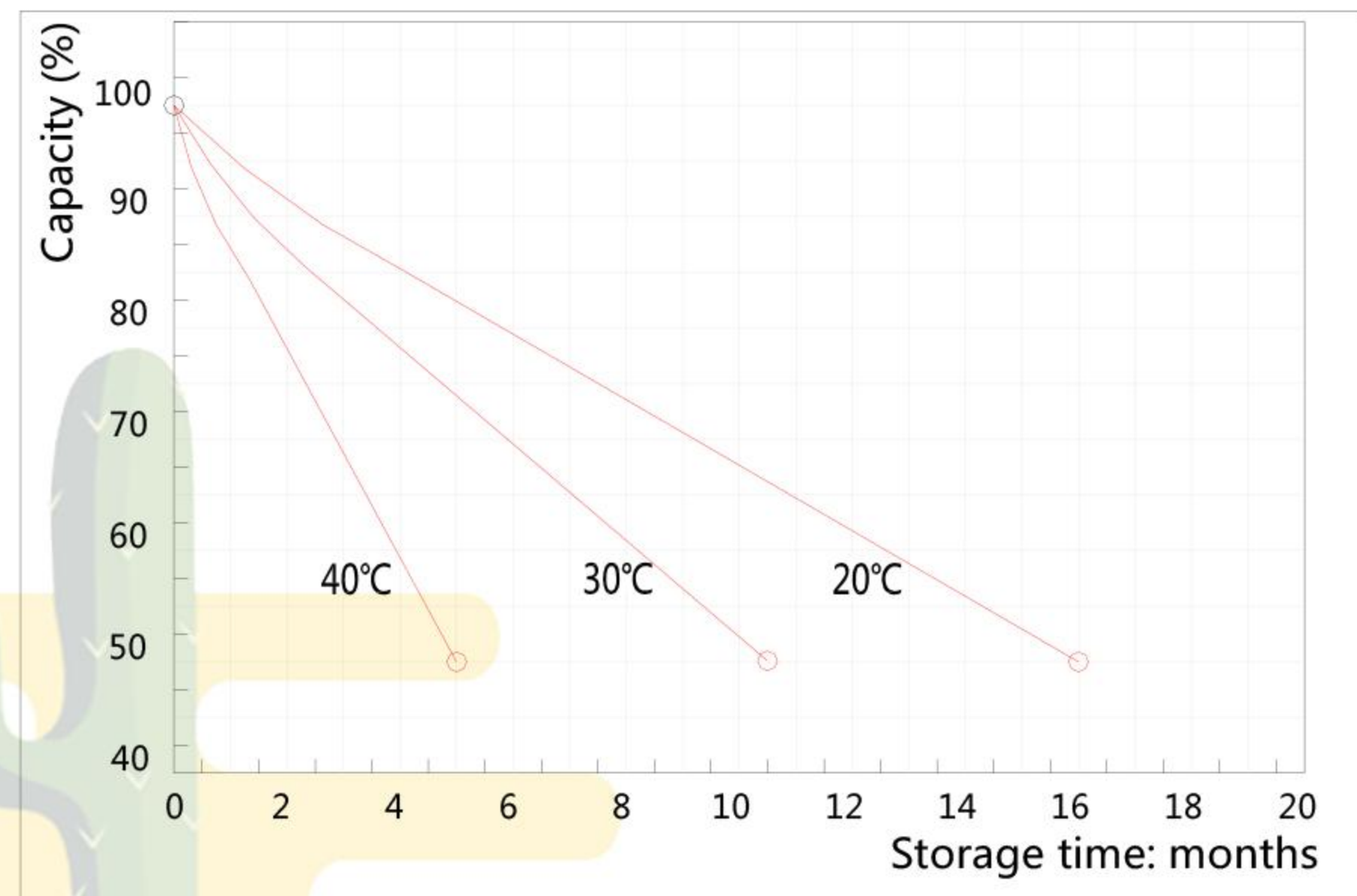

The Relationship for Open Circuit Voltage and Residual Capacity (25°C)

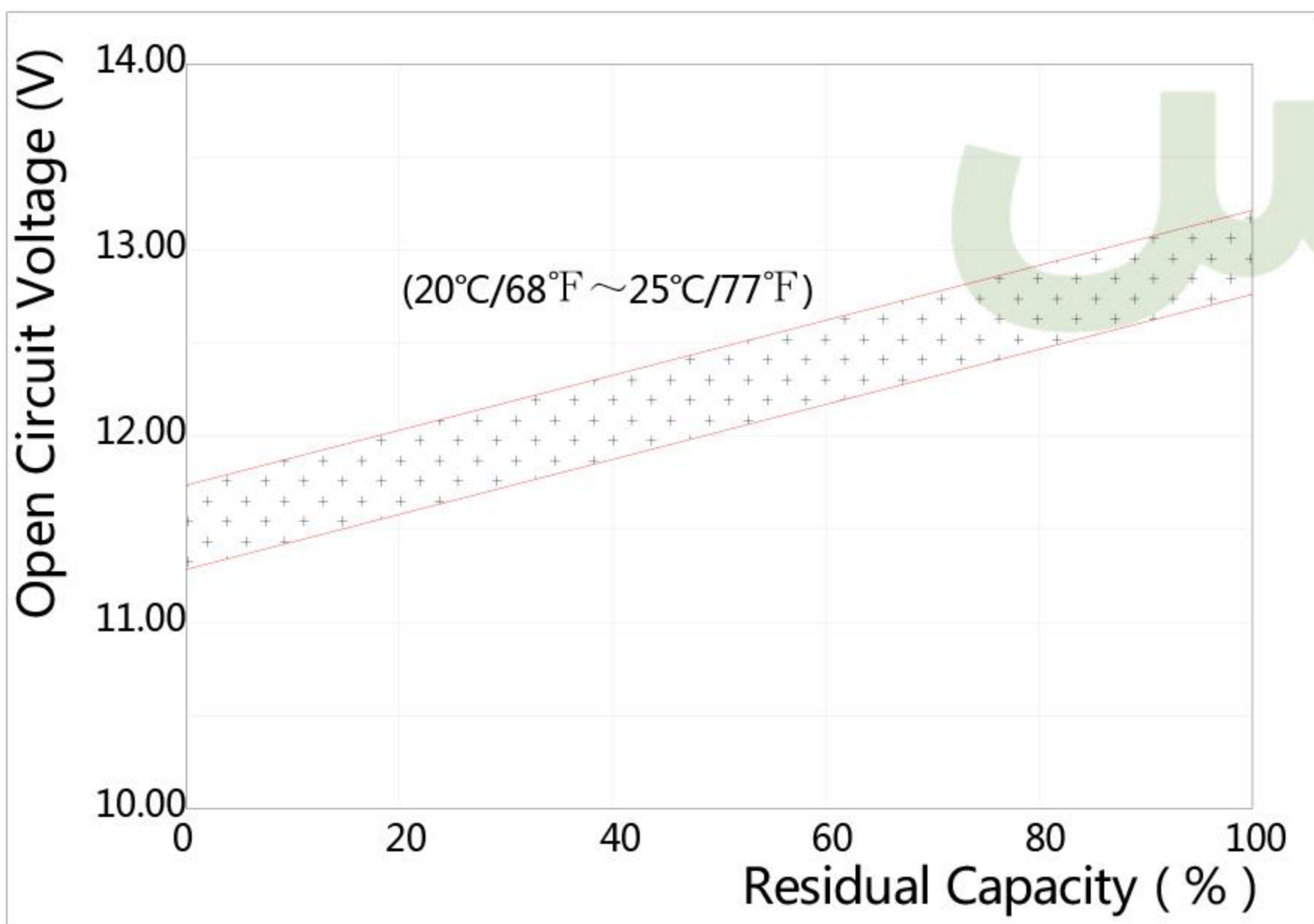

The Relationship for Charging Voltage and Temperature

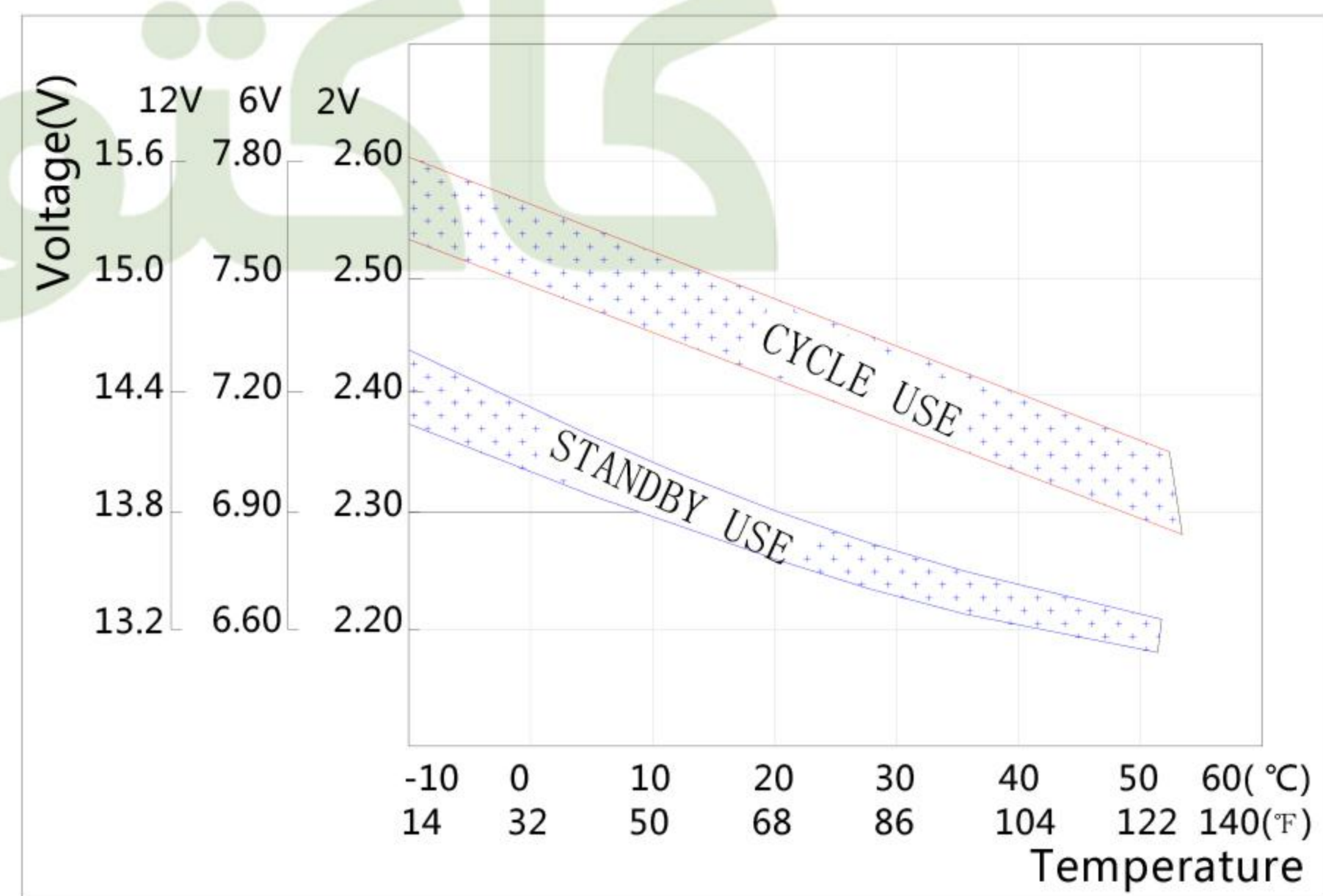

Floating Life on Temperature

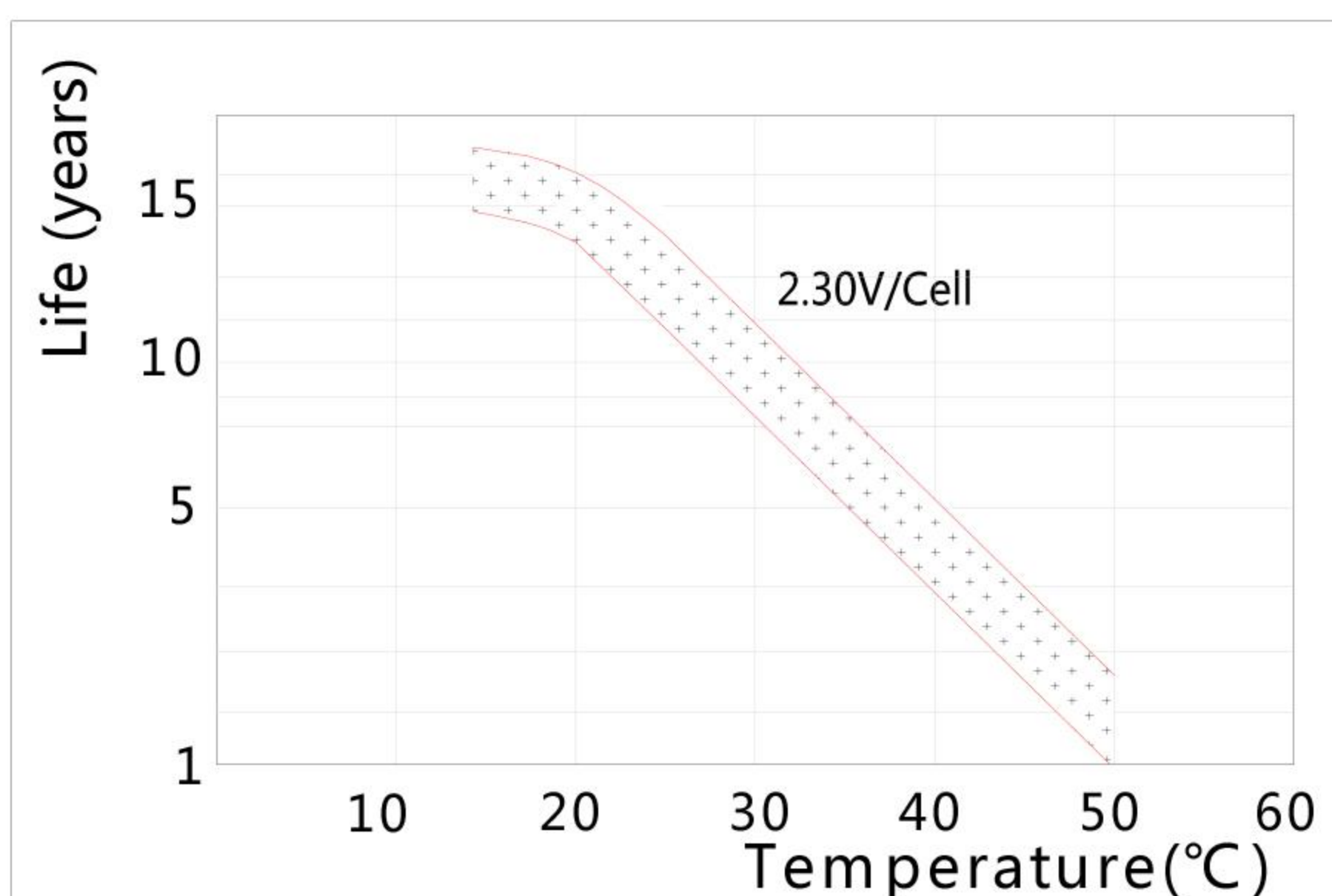

Cycle Life on D.O.D(25°C)

