

**Specifications**

Nominal Voltage		12 V
Capacity (25°C)	10HR(10.8V)	18.0Ah
	5HR(10.5V)	16.8Ah
	1HR(9.60V)	12.8Ah
Dimension	Length	181 ± 2mm (7.13inch)
	Width	77 ± 1mm (3.03inch)
	Height	167 ± 2mm (6.57inch)
	Total Height	167 ± 2mm (6.57inch)
Approx. Weight		5.45kg (12.0lbs) ± 4%
Terminal type		T3/T8
Internal resistance (Fully charged, 25°C)		Approx. 16m Ω
Capacity affected by temperature (20HR)	40°C	102%
	25°C	100%
	0°C	85%
	-15°C	65%
Self-discharge (25°C)	3 month	Remaining Capacity: 91%
	6 month	Remaining Capacity: 82%
	12 month	Remaining Capacity: 65%
Nominal operating temperature		25°C ± 3°C (77°F ± 5°F)
Operating temperature range	Discharge	-15°C ~ 50°C (5°F ~ 122°F)
	Charge	-10°C ~ 50°C (14°F ~ 122°F)
	Storage	-20°C ~ 50°C (-4°F ~ 122°F)
Float charging voltage(25°C)		13.60 to 13.80V Temperature compensation: -18mV/°C
Cyclic charging voltage(25°C)		14.50 to 14.90V Temperature compensation: -30mV/°C
Maximum charging current		5.4A
Terminal material		Copper
Maximum discharge current		270A(5 sec.)
Designed floating life(20°C)		15 years

- ◆ Absorbent glass mat technology;
- ◆ Recognized by UL & CE;
- ◆ ABS container.

**Constant Current Discharge Characteristics (A, 25°C)**

F.V/TIME	10min	15min	30min	60min	2h	3h	4h	5h	8h	10h	20h
1.60V	46.0	36.8	20.5	12.8	7.01	5.04	4.03	3.42	2.22	1.85	0.96
1.65V	44.6	35.9	20.1	12.6	6.98	5.00	4.01	3.40	2.21	1.85	0.96
1.70V	42.8	34.6	19.5	12.3	6.91	4.97	3.98	3.38	2.18	1.84	0.95
1.75V	40.9	33.4	19.0	12.1	6.82	4.94	3.95	3.36	2.17	1.83	0.95
1.80V	38.6	31.6	18.3	11.7	6.64	4.80	3.83	3.26	2.11	1.80	0.94

**Constant Power Discharge Characteristics (Watt ,25°C)**

F.V/TIME	10min	15min	30min	60min	2h	3h	4h	5h	8h	10h	20h
1.60V	519	419	235	148	82.3	59.8	47.9	41.0	26.5	22.4	11.7
1.65V	502	410	230	146	81.7	59.5	47.7	40.6	26.5	22.3	11.6
1.70V	483	394	224	143	81.0	59.1	47.4	40.4	26.2	22.2	11.6
1.75V	462	381	219	140	79.7	58.7	47.1	40.0	26.1	22.1	11.5
1.80V	436	361	209	136	77.7	57.0	45.6	38.9	25.2	21.6	11.3

Note: The above characteristics data can be obtained within three charge/discharge cycles.



**Dimensions**

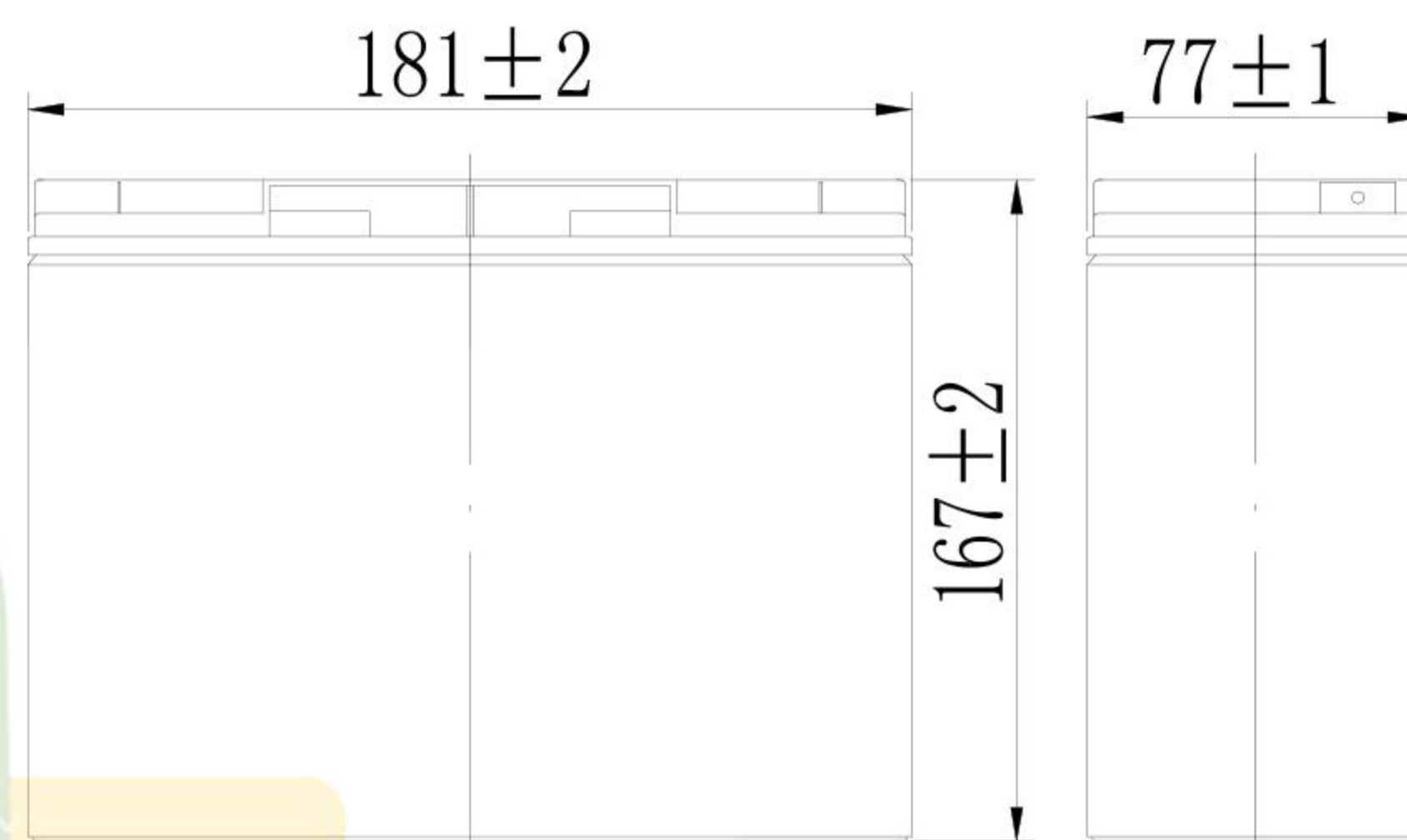

**Terminal**

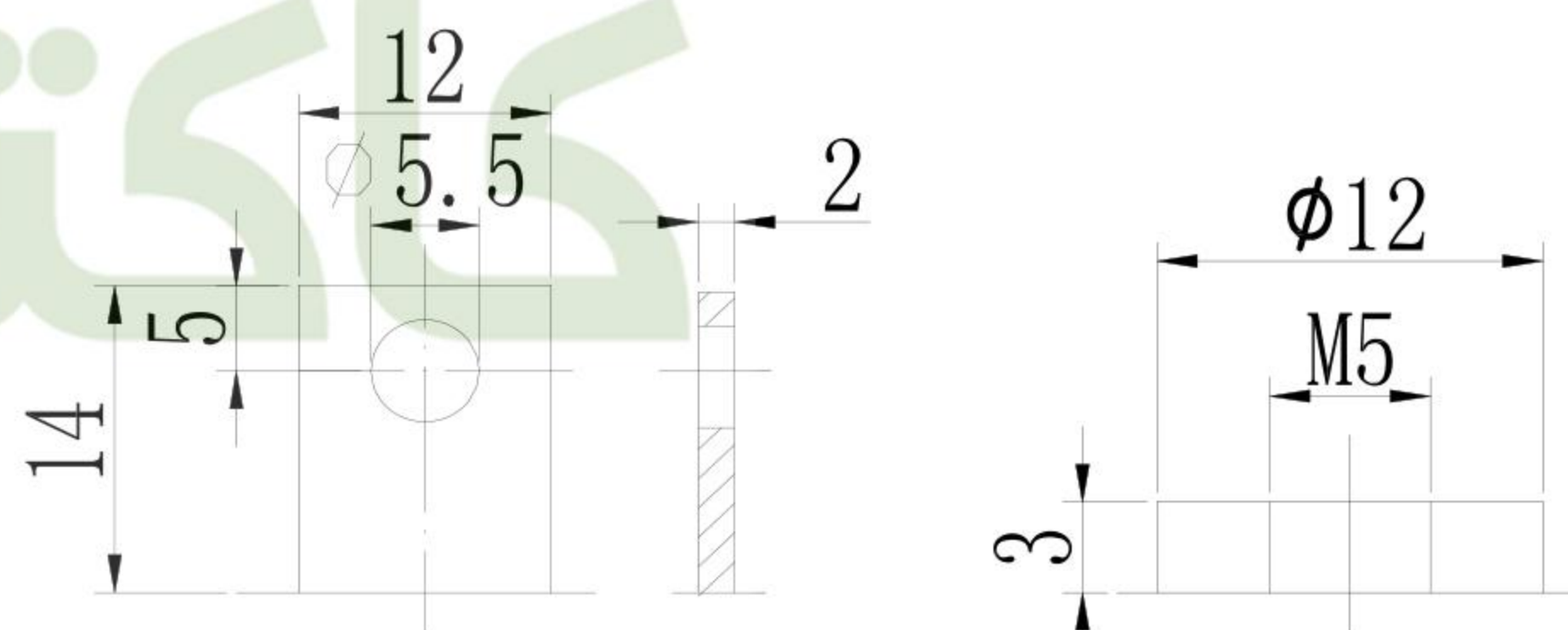

Terminal T3

Terminal T8

Discharge Characteristics(25°C)

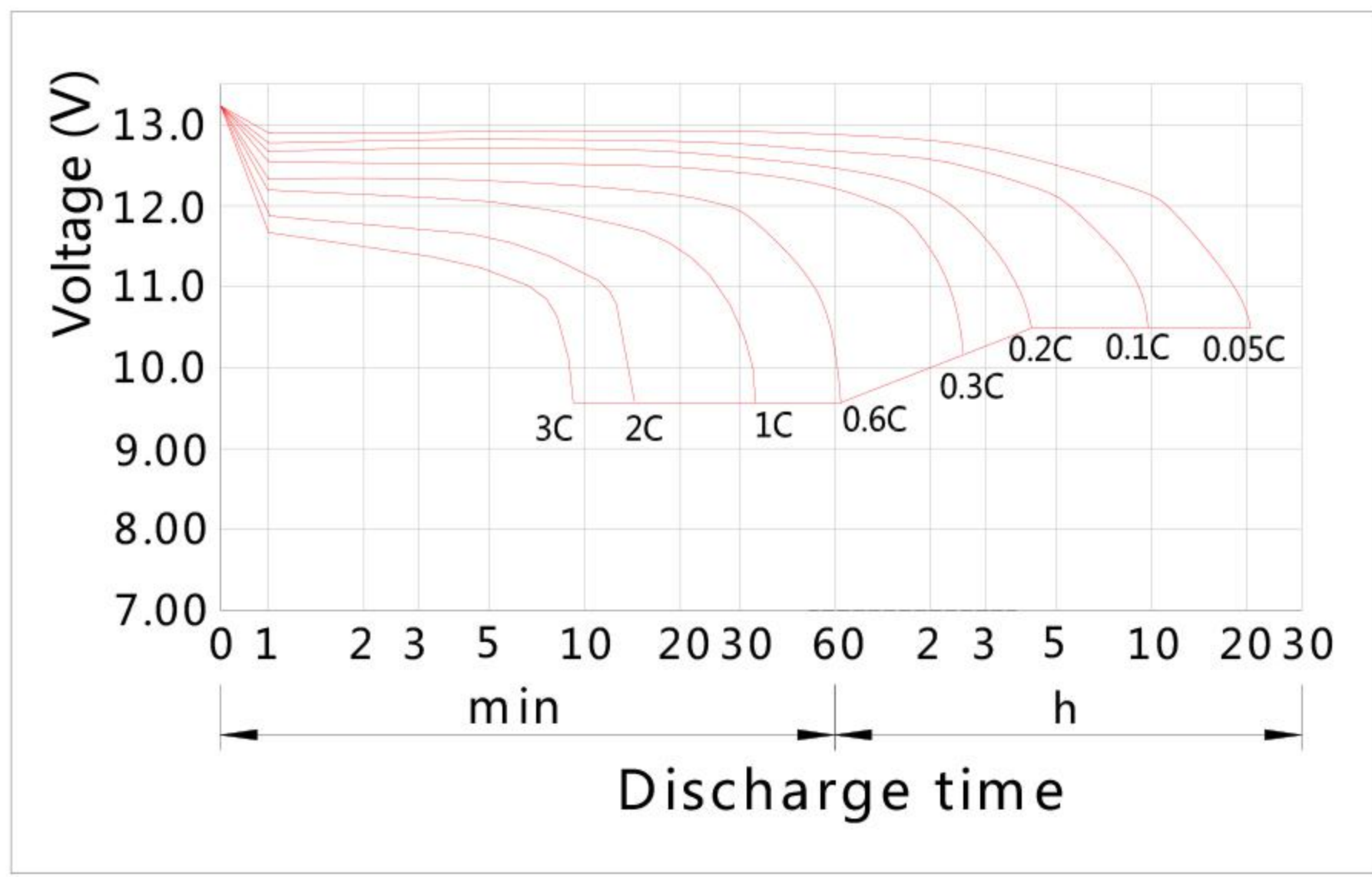

Charging Characteristics(25°C)

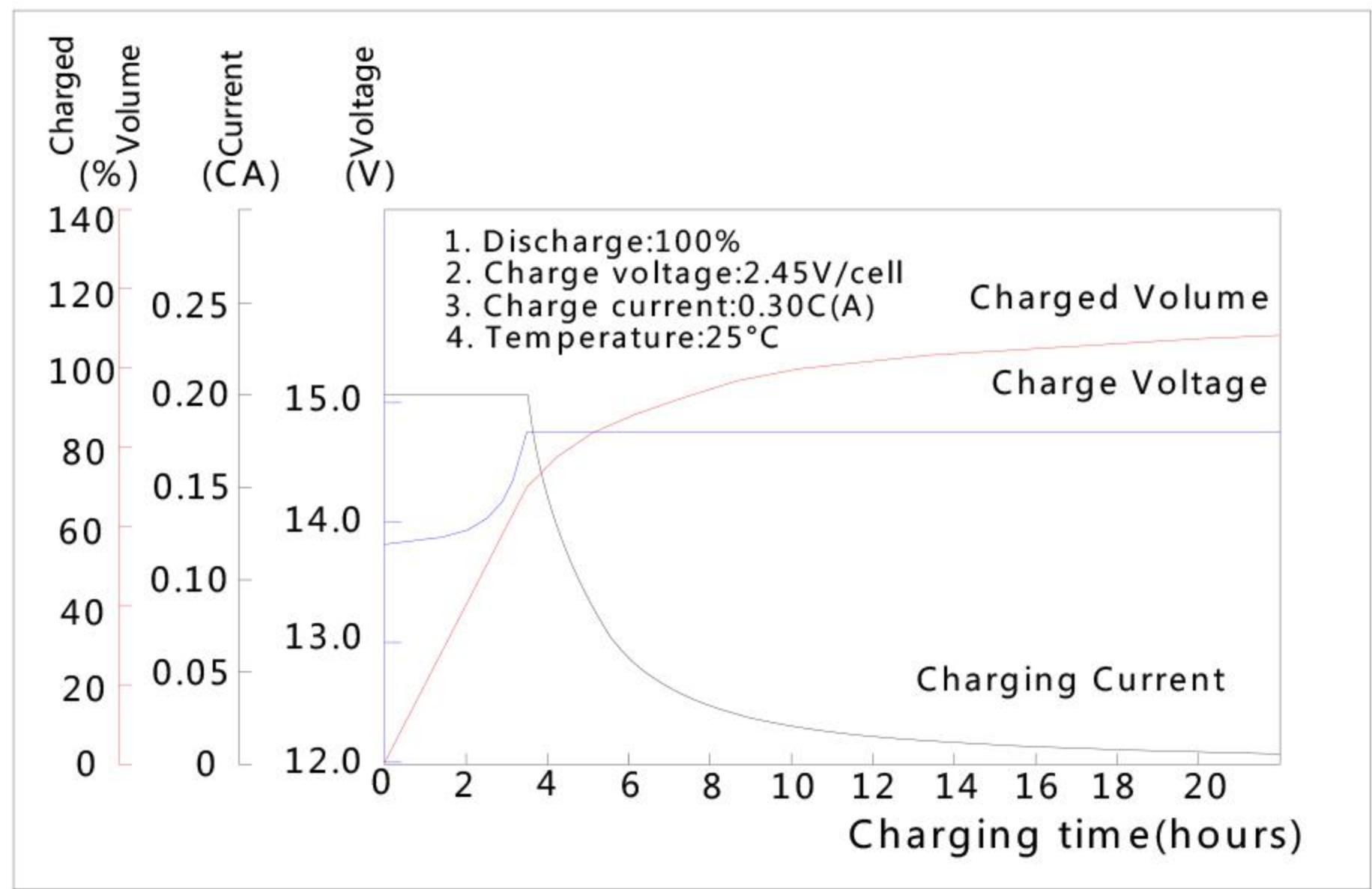

Effect of Temperature on Capacity

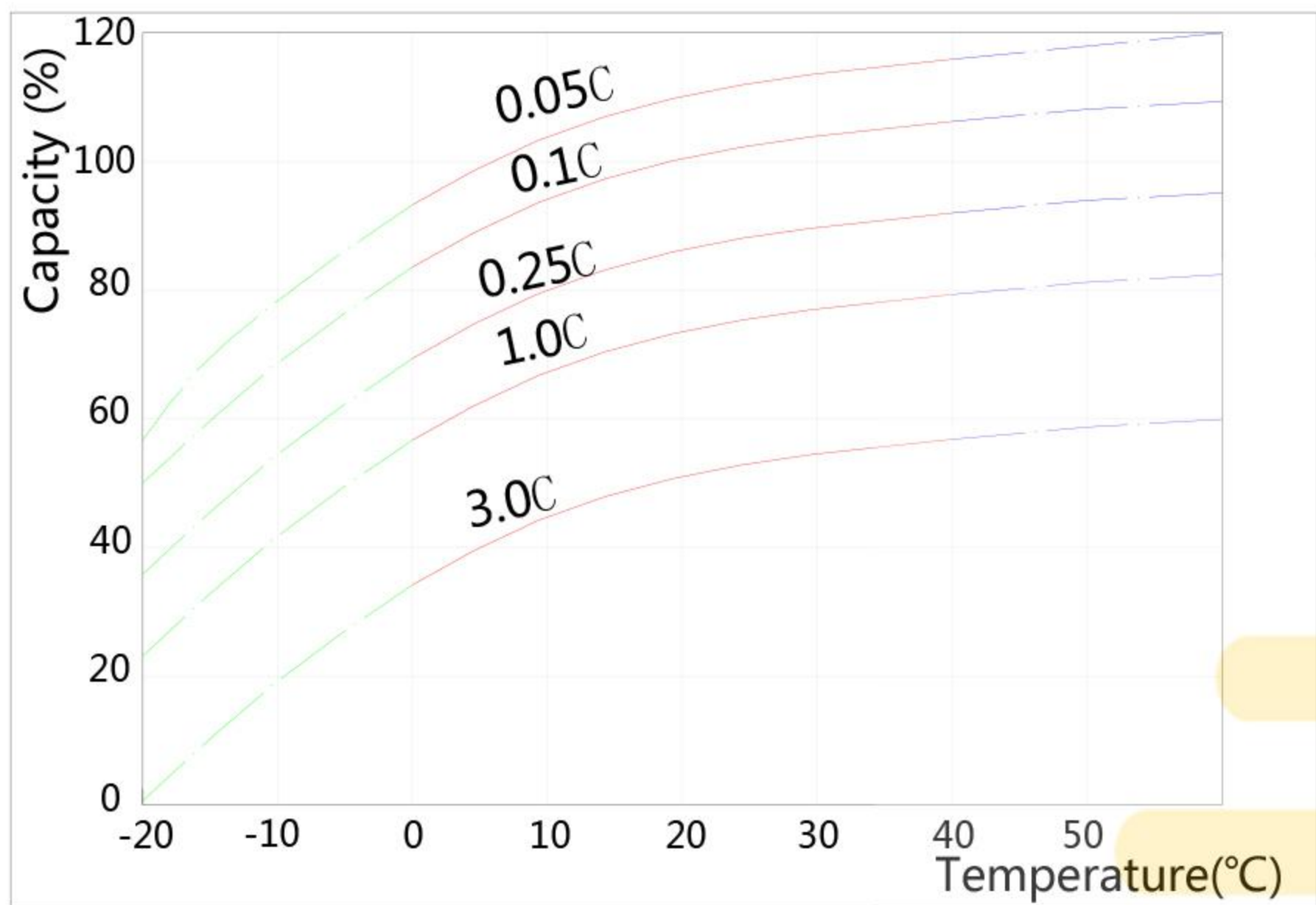

Self-discharge Characteristics

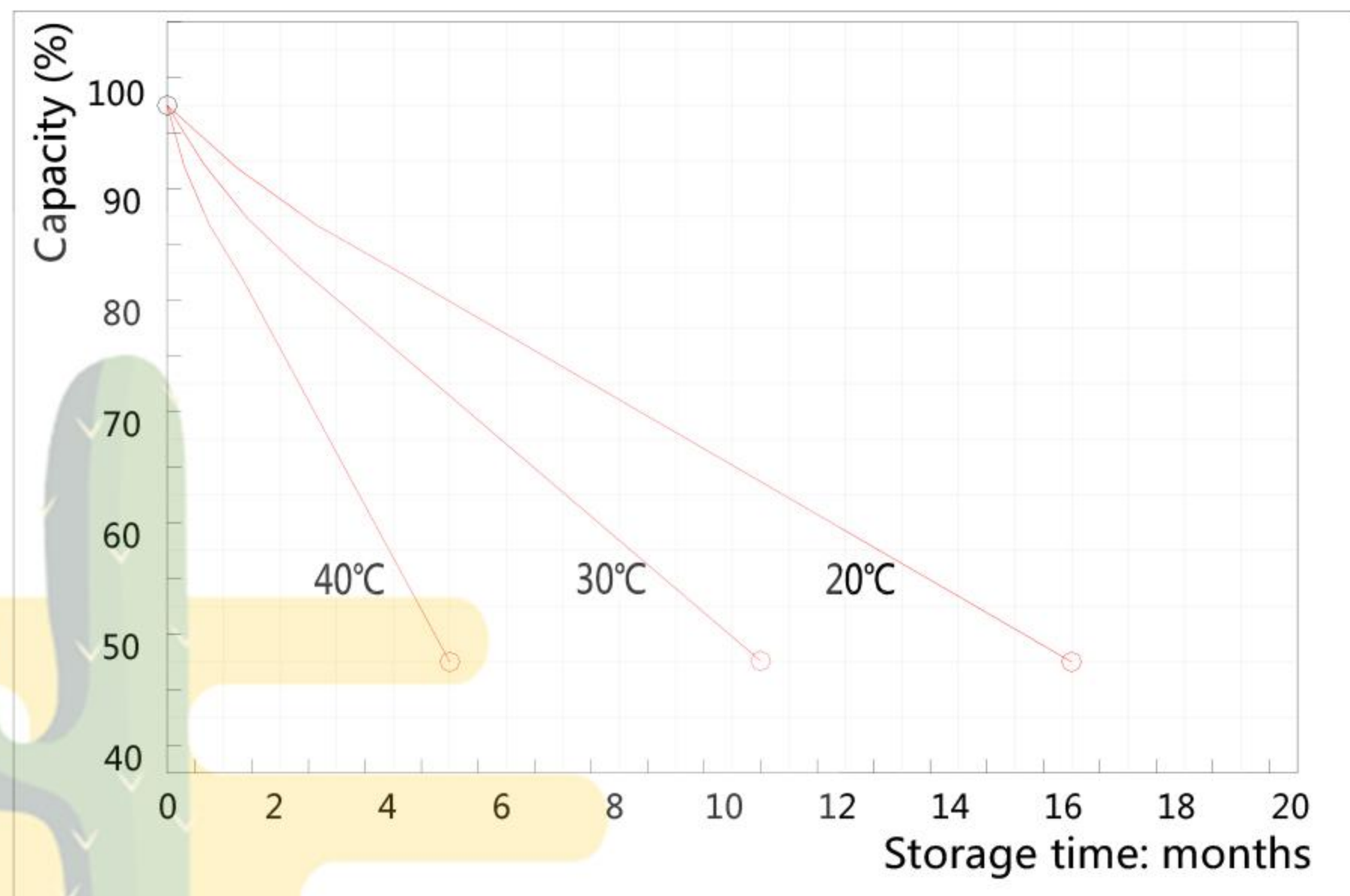

The Relationship for Open Circuit Voltage and Residual Capacity (25°C)

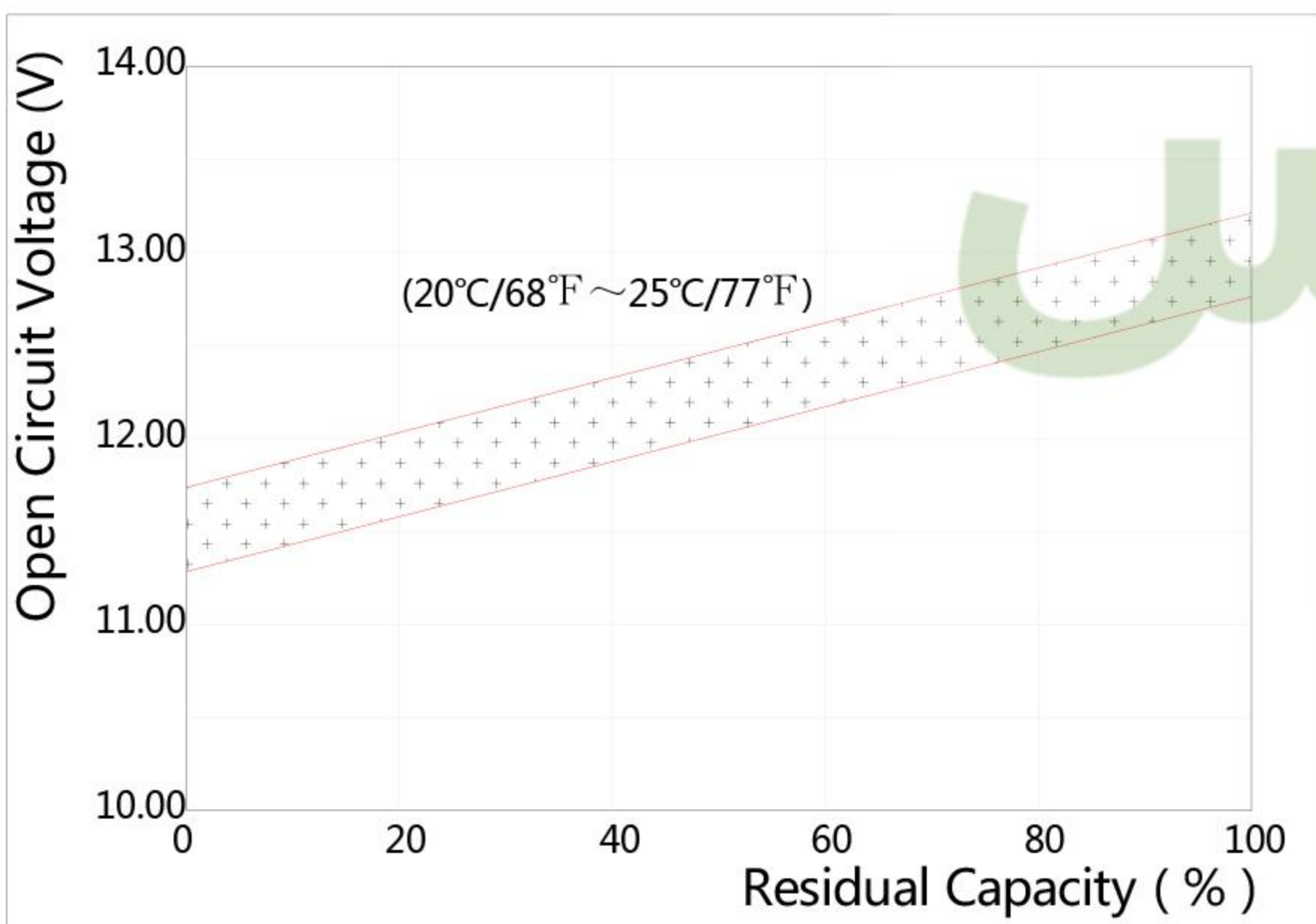

The Relationship for Charging Voltage and Temperature

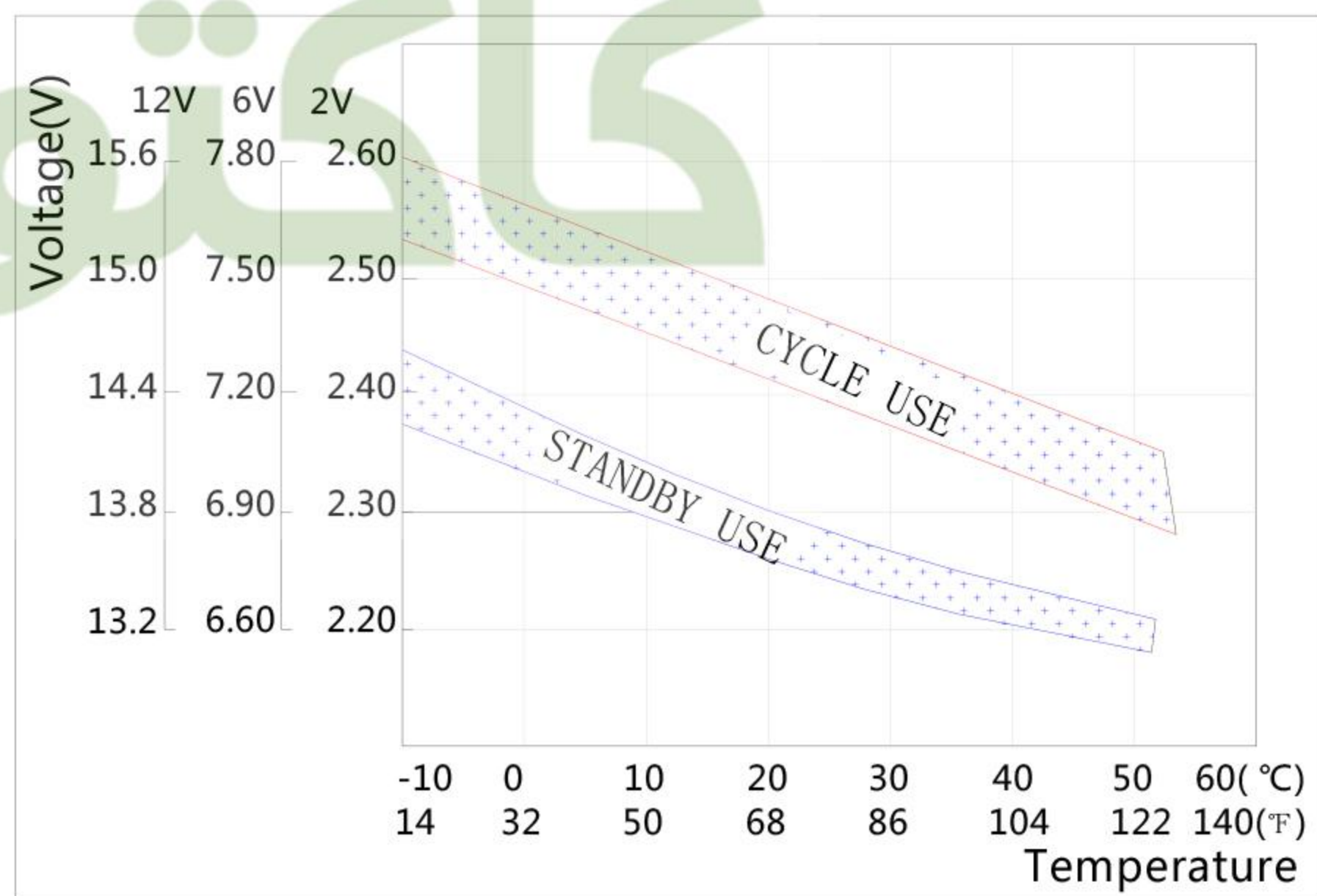

Floating Life on Temperature

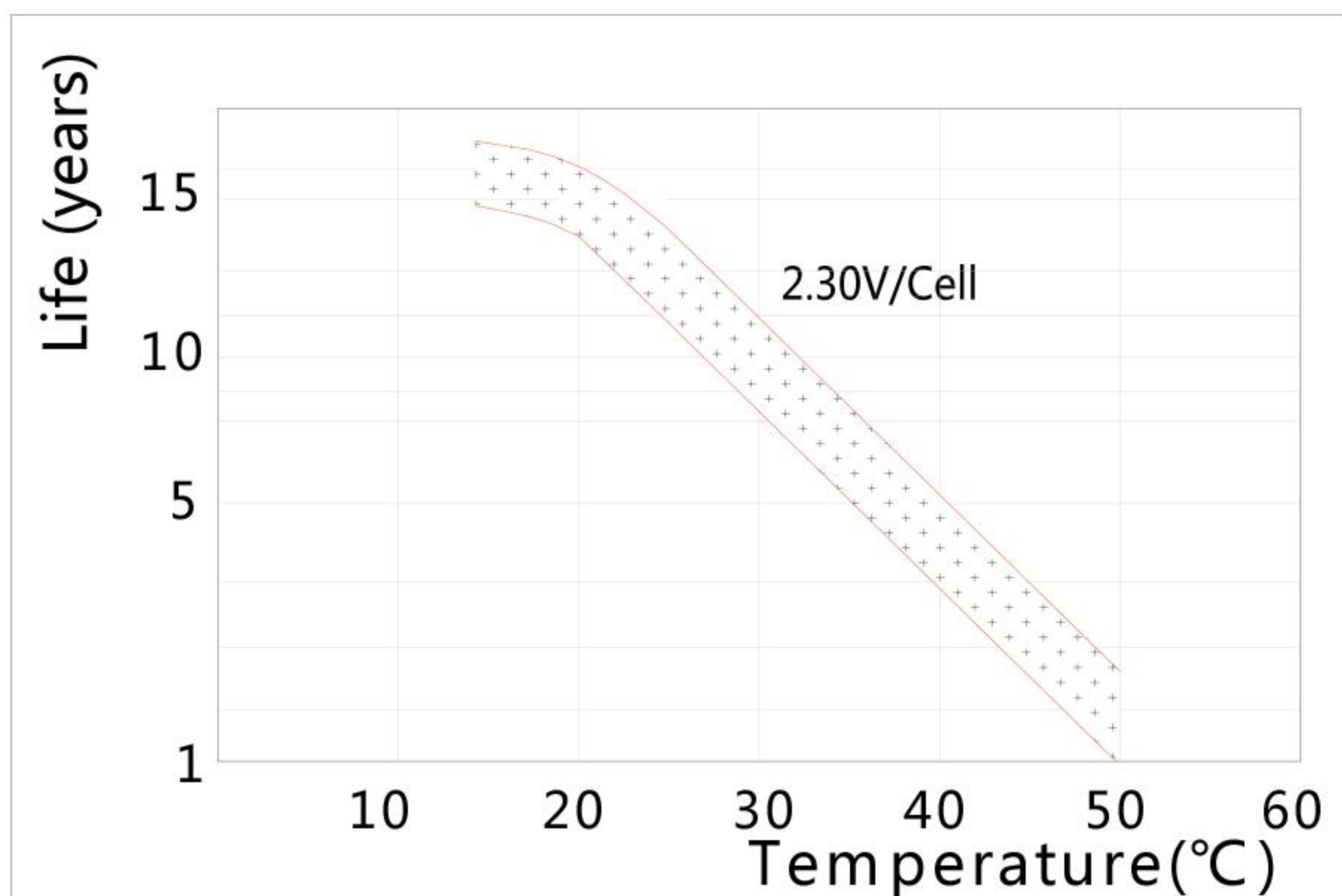

Cycle Life on D.O.D(25°C)

